



VICTORY
ADVANCED TECHNOLOGIES



PRODUCT DATA SHEET

Our rugged high-performance motors are designed for extreme operating conditions and backed by an industry leading four-year replacement warranty



REPLACEMENT WARRANTY

Anodized Aluminum

Corrosion Resistant

Fully potted **IP67** Waterproof

Rated **EX** for hazardous locations

Drop -In Replacement

Coast to Coast Sales & Service

Quality Control

Polarity Reversal



Standard Hose Reel Motor

series - EX



P/N: HRMA-56S-12V



HRMA-56S-12V: Explosion-Proof Hose-Reel Motor

Technical Data

Diameter Length	8.259" 6.384"
Cooling	Air
Ingress Protection	IP67
Weight [lb]	30 lb
Installation	NEMA 56D
Max Speed	1010 RPM
Stall Torque	12.9 lb·ft 17.5 N·m
Max Power	0.67 HP
Max Efficiency	50% @ 500 RPM
Operating Voltage	12 VDC
Duty	5 min.
Speed Control	No

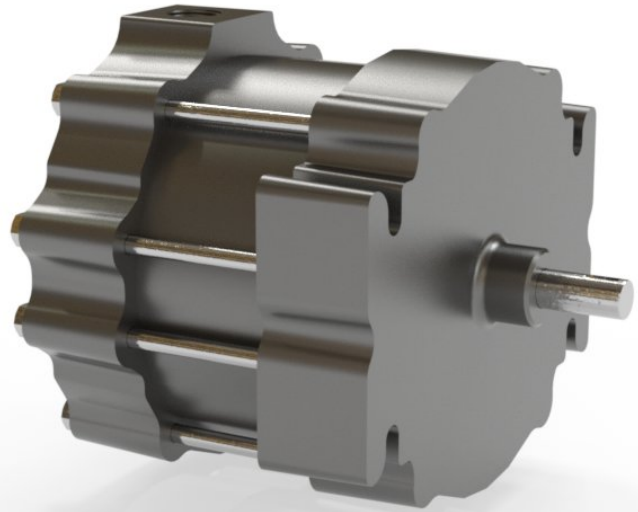

Torque-Speed Curve

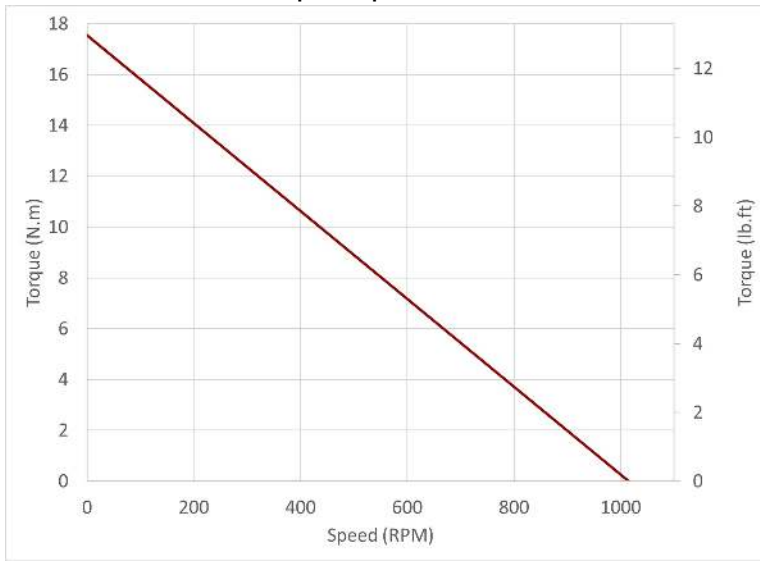

Power-Speed Curve

