



VICTORY
ADVANCED TECHNOLOGIES



PRODUCT DATA SHEET

Our rugged high-performance motors are designed for extreme operating conditions and backed by an industry leading four-year replacement warranty

Fully potted **IP67** Waterproof

Rated **EX** for hazardous locations

Easy remote control system interface

Brake interlock (lock reel in place)

Cost savings on new installations

Automatic Hose unwind assist

Speed selection (Reel In/Out)

Soft start/stop (reel In)

Simplified Installation

Built In Junction Box



REPLACEMENT WARRANTY

Anodised Aluminium
Corrosion Resistant



Smart Hose Reel Motor

series - EX

P/N: HRMA-56S-12V SMT





HRMA-56S-12V-SMT: Explosion-Proof Hose-Reel Smart Motor

Technical Data

Diameter Length	8.259" 5.348"
Cooling	Air
Ingress Protection	IP67
Weight [lb]	25.4 lb
Installation	NEMA 56D
Max Speed	1268 RPM
Stall Torque	17.3 lb·ft 23.4 N·m
Max Power	0.67 HP
Max Efficiency	74% @ 600 RPM
Operating Voltage	12 VDC
Duty	5 min.
Speed Control	Yes (10 Speed)

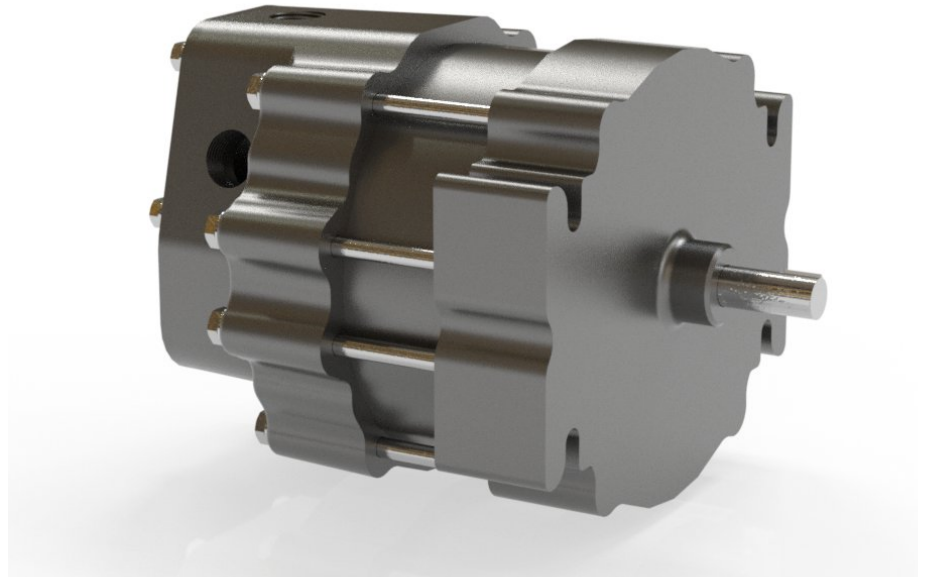

Torque-Speed Curve

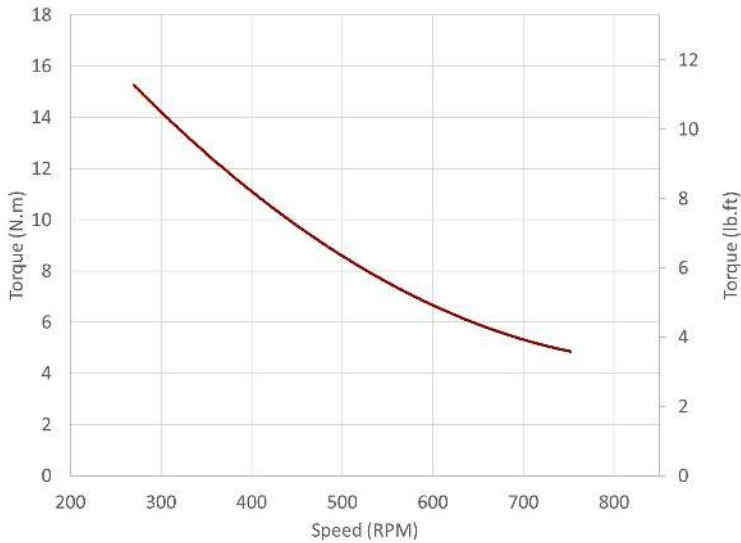

Power-Speed Curve

